



## INSTALLATION, OPERATION AND MAINTENANCE INSTRUCTIONS

HORIZONTAL AND VERTICAL TUBE  
AEROMIX® HOT WATER / STEAM  
INTEGRAL FACE & BYPASS COILS



**Vertical Tube**  
VMW, VMX, AMW, AMX  
Plate Fin or Spiral Fin

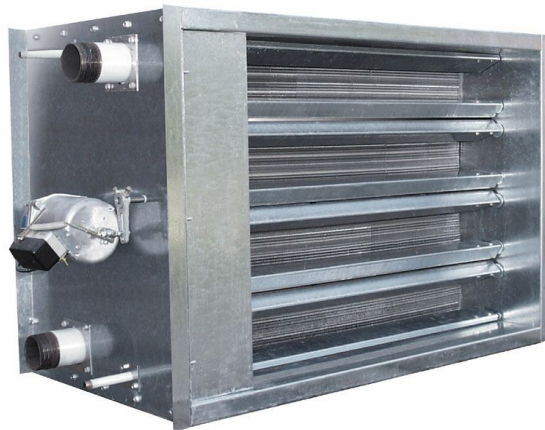

**Horizontal Tube**  
HMW, HMX  
Plate Fin

**AEROFIN** LYNCHBURG, VA 1-800-AEROFIN

Thank you for purchasing this quality Aeromix® integral face and bypass coil. Your coil was shipped from our factory in perfect working order. Some adjustment in the linkage may be needed prior to system startup due to handling during shipment, storage, and installation. Visit our website at [www.aerofin.com](http://www.aerofin.com) for product information, recommended piping diagrams, linkage adjustment instructions, operation and maintenance instructions, and warranty limitations.

## TABLE OF CONTENTS

I.	STORAGE .....	3
II.	COIL INSTALLATION .....	3
III.	GENERAL PIPING INSTALLATION .....	3
IV.	STEAM PIPING INSTALLATION .....	3
V.	HOT WATER PIPING INSTALLATION .....	4
VI.	CONTROLS INSTALLATION .....	4
VII.	STARTUP .....	5
VIII.	OPERATION .....	5
IX.	SHUT DOWN .....	6
X.	MAINTENANCE INSTRUCTIONS .....	6
XI.	STEAM COIL TROUBLESHOOTING .....	6
XII.	WARRANTY .....	7
XIII.	SPARE PARTS .....	8
XIV.	APPENDIX .....	8

## **I. STORAGE**

Indoor storage is recommended . Where indoor storage is not possible, all items should be stored off the ground and under cover. If any moisture enters the coil, make sure that the coil is stored in a way that allows it to drain out the connections.

## **II. COIL INSTALLATION**

- A. Locate the lifting provisions provided on the coil. Refer to the Aeromix<sup>®</sup> catalog located on our website at <http://www.aerofin.com> for the coil weight to ensure adequate lifting equipment is used. A spreader bar is recommended.
- B. Care should be taken to prevent damaging the coil connections during handling.
- C. Lift the coils and place them into the air handling unit (AHU) or duct.
- D. If connecting the coil directly to ductwork, do not remove the lifting equipment until the coil has been firmly secured to the inlet and outlet duct and is adequately supported.
- E. All ducts and AHU's should be adequately insulated and sealed to minimize heat losses and leaks.
- F. Filters, when used, should be located on the entering airside of the coil to filter out oil, dust, lint, and soil, which might foul the surface of the coil.
- G. A minimum distance of 36" should be allowed down stream of the coil for adequate mixing of bypassed and heated air.

## **III. GENERAL PIPING INSTALLATION**

- A. Supply and return piping shall be supported independently of the coil.
- B. Do not use the coil connections as anchors for the piping system.

## **IV. STEAM PIPING INSTALLATION**

- A. Refer to the piping guideline in the appendix.
- B. Full sized condensate piping shall be maintained from the coil to the steam trap. Do not reduce the condensate pipe size at the coil outlet.
- C. Float-Thermostatic traps or bucket traps should be used for condensate removal. The trap may also have a combination vent. The trap size shall be selected using 2.5 times the rated condensate flow from the coil and the pressure differential between the steam supply and condensate return mains at which it will operate. Thermostatic traps shall be used for venting only.
- D. A separate trap on each coil is recommended for best results.

- E. If check valves are used in the system, 15 degree swing check valves which open with a lower head of water are recommended . Ball, piston, or 45 degree swing check valves are not recommended for use.
- F. Condensate drips should be piped into the return main downstream of the steam trap. Do not drip condensate into coil supply.
- G. Ensure that the steam control valve is properly sized.
- H. A pump and receiver tank or a steam pump should be installed between the steam trap and an overhead condensate return main. Condensate should not be lifted to an overhead main using only the steam pressure. Do not drain condensate to a pressurized return main.
- I. Strainers should be used on the steam supply side of the coil to collect scale or debris. 3/32" mesh is recommended.
- J. Steam coils must have provision for venting non-condensable gases (such as air and carbon dioxide) which are removed from condensing steam. Build up of non-condensable gases will reduce heating capacity and can cause the system to corrode. Provide venting as shown in the piping diagrams at the coil outlet.
- K. Do not fail to use a vacuum breaker (15 degree swing check valve installed to let air into the system) on steam heating units as shown in the piping diagrams. This provision is essential for drainage of condensate should the unit see a vacuum condition when modulating the steam pressure or upon shut down when the supply steam is turned off. The vacuum breaker should be installed at the coil outlet, as this is the point of lowest pressure. Vacuum breaker installation at the coil inlet is not recommended .

## **V. HOT WATER PIPING INSTALLATION**

- A. Refer to the piping guideline in the appendix.
- B. If one valve is used in lieu of two, install it on the return line.
- C. Pipe 2-row or 3-row coils for counterflow heat transfer between the air and water.

## **VI. CONTROLS INSTALLATION**

- A. The required leaving air temperature from the unit is maintained by automatic positioning of the face & by-pass dampers via an electric or pneumatic actuator in response to a thermostat downstream of the unit.
- B. Use an averaging type sensing element. If the coil has vertical tubes, arrange the sensing element horizontally across the face & by-pass sections. If the coil has horizontal tubes, arrange the sensing element vertically across the face & by-pass sections.
- C. Do not place the temperature sensing element closer than 36" inches from the face of the Aeromix<sup>®</sup> coil to allow for air mixing.

- D. If the coil is equipped with a factory-installed actuator, only minor adjustment should be necessary. See paragraph H below for adjustment guidance.
- E. For a field mounted actuator, attach the actuator to the damper control shelf (vertical tube coil) or to the side of the casing (horizontal tube coil). Mounting holes may be drilled as necessary to accommodate attachment hardware.
- F. Consult the actuator documentation for applicable electrical wiring diagrams or pneumatic line installation instructions.
- G. Follow the controller manufacturer's instructions for interfacing the electric or pneumatic actuator to the thermostat in the air stream. Consult the actuator documentation for fail-safe requirements.
- H. Ensure that the actuator moves the dampers to a fully closed (heating) position and reverses to a fully open (bypass) position. Make sure that there is no binding in the linkage. If necessary, disconnect the linkage at the fully closed position and reconnect the actuator so that the crank arms will move in agreement. With a vertical tube coil, there should be no need to adjust the threaded push/pull rods because these rods are factory set at the proper length.  
Follow the actuator manufacturer's instructions for adjustment of the actuator when required.
- I. Set the thermostat so that the dampers open and the bypass closes when heat is required.

## **VII. STARTUP**

- A. Prior to startup with steam, verify that the coil is completely drained of all condensate.
- B. The steam or hot water supply shall be started prior to start of airflow.
- C. Allow time for all air to be purged from the piping system and for the finned tubing to reach full heat to prevent heating lag.
- D. Preheating a cold system with the damper doors closed (heating mode) will avoid excessive condensate loading at the startup of a steam system. Preheating will also help protect against freezing of steam and hot water units when subject to sub-freezing air temperatures.
- E. After preheating, fully open the dampers for heating (bypass closed). Set thermostat for desired air temperature.
- F. Start airflow.

## **VIII. OPERATION**

- A. Aeromix<sup>®</sup> coils are designed for continuous operation. They respond to temperature changes by opening and closing the damper doors.

- B. Steam: The supply steam pressure may be modulated for reduced heating capacity during the warmer portion of the heating season if desired. The steam coils feature inner distributing tubes for uniform and even heating under low load conditions.
- C. Hot Water: The supply water temperature may be modulated for reduced heating capacity. If a temperature sensing element is used in the return piping, then set it to sustain a leaving water temperature not less than 100°F. If the entering air temperature is 32°F or less, do not modulate the water through the coils below a flow rate of 2.0 feet/second per circuit. Refer to Table A in Appendix for the minimum water flow rate in GPM (gallons per minute).

## **IX. SHUT DOWN**

- A. On shut down, stop the airflow before turning off the steam or hot water supply. This is imperative when the unit is heating sub-freezing air temperatures.
- B. With the airflow off, the steam or hot water supply should remain on when the coil is exposed to sub-freezing temperatures if the coil will not be disconnected and allowed to drain completely.
- C. Drain the coil free of water/condensate as soon as possible. Water left standing in the system may result in freeze damage.

## **X. MAINTENANCE INSTRUCTIONS**

- A. Periodic inspection is recommended for optimum performance of the coils. Accumulation of dust, lint, oil, etc. will cause clogging and fouling of the fin surface and affect damper operation.
- B. External cleaning of the coil fins may be done by spraying with steam, hot water, compressed air, or non-corrosive solvents. Direct high-pressure blast should be avoided. When cleaning with a solvent, neutralize per the manufacturer's instructions and rinse with clean water.
- C. Check for worn or loose linkage parts and smooth damper operation. Readjustment of the linkage may be necessary. Spraying the moving parts with a lubricant such as silicone or WD-40 may improve the operation.
- D. Strainers, drip legs, dirt pockets and steam traps in the piping system should be inspected and cleaned periodically.

## **XI. STEAM COIL TROUBLESHOOTING**

- A. Check piping both on the steam side as well as the condensate side for all necessary components. See the appendix for recommended piping guidelines.
- B. Check the type and capacity of traps. See Section IV. C.
- C. Check the system for any backpressure on the condensate side. Backpressure will reduce the trap capacity.

- D. Verify that the steam inlet has a drip trap installed so that dry steam enters the coil.
- E. Verify that the airflow to coils is evenly distributed and is per the rating. At cold temperatures, air density increases and may reduce the leaving air temperature unless accounted for. (Dirty filters, 90° elbow in duct at coil inlet, obstructions, etc. will affect coil performance.)
- F. Check to make sure that the air temperature is uniform when mixing outside and recirculated air.
- G. If traps are old or worn, they may need to be refurbished to clean ports and vents.
- H. Verify that the return line pressure downstream of the trap is lower than the pressure at trap inlet.
- I. Energize the coil with steam, start the airflow, and check the leaving air temperature.
  - a. If the air temperature is lower than the rating, try bypassing the trap or blowing condensate to drain and letting steam run for a period (15 min.) while maintaining coil pressure. Note: this should be done with steam pressure at the coil of approximately 10 psig. This will determine if the coil is not properly vented or draining.
  - b. If temperature deficiencies exist at low pressures, verify that the vacuum breaker is in working order.

## **XII. WARRANTY**

- A. We warrant for a period not in excess of 12 months from date of shipment the design, construction and materials of our products to be (first-class, and) free from defects in materials and workmanship when properly installed and operated, at pressures and temperatures not exceeding those specified. Our sole obligation under this warranty is limited to repairing or furnishing (replacement thereof), without charge, f.o.b. our factory, any defective part. We will not be responsible for damages of any nature, resulting from the above stated Warranty or from any defect in our products, either in material, design, or construction, or arising from the use of such products.
- B. We do not warrant against water hammer, corrosion, erosion, or abrasion.
- C. Improper piping and/or operation contrary to the instructions provided in this manual will void the warranty.

### **XIII. SPARE PARTS**

- A. There are no spare parts available for these coils
- B. To order replacement coils call (800) AEROFIN or visit our website at <http://www.aerofin.com> for the location of the nearest Aerofin regional sales office.

### **XIV. APPENDIX**

Table A: Minimum Water Flow Required

Aeromix - S: General Steam System Piping Guidelines

Aeromix - HW: General Hot Water System Piping Guidelines

TABLE A – Minimum Water Flow Required For Entering Air <= 32°F

AMIX Spiral Fin Hot Water Coils

Tube Face	Circuit	GPM	Circuit	GPM	Circuit	GPM	Circuit	GPM	Circuit	GPM
8	Full	12.1	Half	6.0	1/4	3.0	3/4	9.0	1.5	18.1
12	Full	18.1	Half	9.0	1/4	4.5	3/4	13.6	1.5	27.1
16	Full	24.1	Half	12.1	1/4	6.0	3/4	18.1	1.5	36.2
20	Full	30.1	Half	15.1	1/4	7.5	3/4	22.6	1.5	45.2
24	Full	36.2	Half	18.1	1/4	9.0	3/4	27.1	1.5	54.3
28	Full	42.2	Half	21.1	1/4	10.6	3/4	31.7	1.5	63.3
32	Full	48.2	Half	24.1	1/4	12.1	3/4	36.2	1.5	72.3
36	Full	54.3	Half	27.1	1/4	13.6	3/4	40.7	1.5	81.4
40	Full	60.3	Half	30.1	1/4	15.1	3/4	45.2	1.5	90.4
44	Full	66.3	Half	33.2	1/4	16.6	3/4	49.7	1.5	99.5
48	Full	72.3	Half	36.2	1/4	18.1	3/4	54.3	1.5	108.5

VMW Plate Fin Hot Water Coils

Tube Face	Circuit	GPM	Circuit	GPM	Circuit	GPM	Circuit	GPM	Circuit	GPM
8	Full	15.0	Half	7.5	1/4	3.8	3/4	11.3	1.5	22.6
12	Full	22.6	Half	11.3	1/4	5.6	3/4	16.9	1.5	33.9
16	Full	30.1	Half	15.0	1/4	7.5	3/4	22.6	1.5	45.1
20	Full	37.6	Half	18.8	1/4	9.4	3/4	28.2	1.5	56.4
24	Full	45.1	Half	22.6	1/4	11.3	3/4	33.9	1.5	67.7
28	Full	52.7	Half	26.3	1/4	13.2	3/4	39.5	1.5	79.0
32	Full	60.2	Half	30.1	1/4	15.0	3/4	45.1	1.5	90.3
36	Full	67.7	Half	33.9	1/4	16.9	3/4	50.8	1.5	101.6
40	Full	75.2	Half	37.6	1/4	18.8	3/4	56.4	1.5	112.9
44	Full	82.8	Half	41.4	1/4	20.7	3/4	62.1	1.5	124.1
48	Full	90.3	Half	45.1	1/4	22.6	3/4	67.7	1.5	135.4



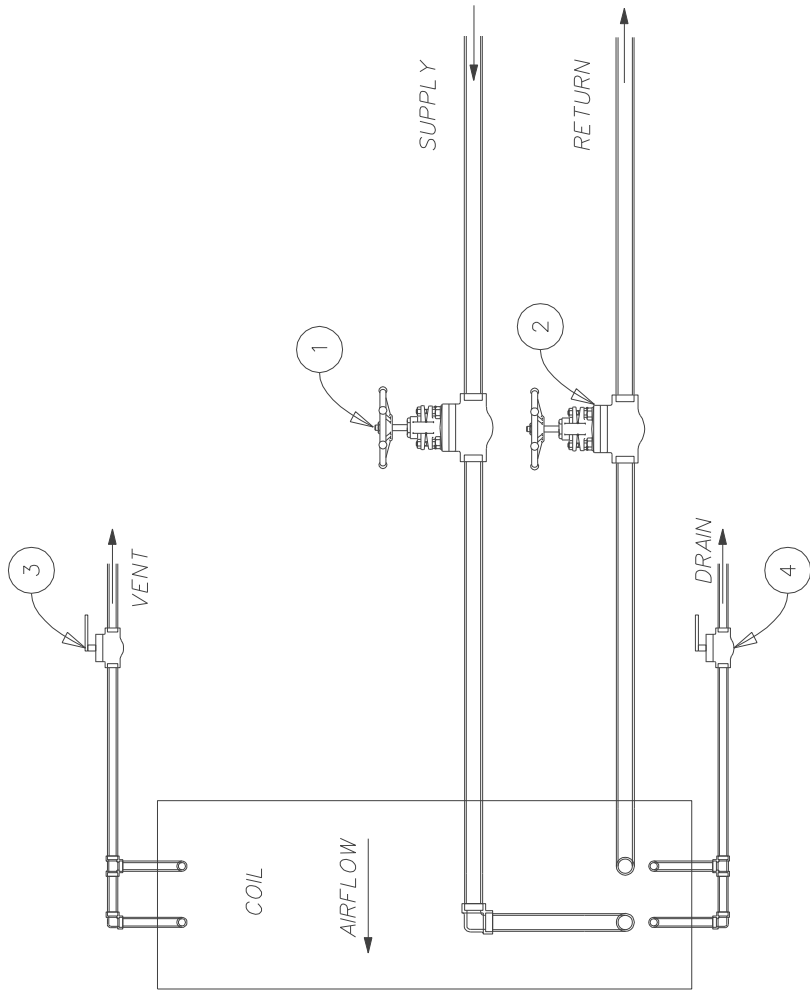

NOTE: THESE GUIDELINES ARE TYPICAL AND NOT INTENDED TO ADDRESS ALL SITUATIONS OR POSSIBLE ALTERNATIVES NEEDED TO MEET INDIVIDUAL SITE REQUIREMENTS.

PIPE FOR COUNTERFLOW. CONTROL VALVE SHOULD BE ON OUTLET OF COIL

- 1 ISOLATION GATE VALVE
- 2 MODULATING CONTROL VALVE
- 3 BALL VALVE - VENT
- 4 BALL VALVE - DRAIN

A	CHECKED	7/12/07	RAM	GLC
NO	REVISION	DATE	DR	ENG

**AEROFIN CORP.**  
LYNCHBURG, VA.

TITLE:

GENERAL HOT  
WATER SYSTEM  
PIPING GUIDELINES

DWG.NO. AEROMIX - HW